



## Land Use Consent Application For Works in or on the Beds of Lakes and Rivers

The information you supply should be detailed according to the scale, scope and effects of the proposed activity.

For small scale proposals having minor effects you should be able to supply sufficient information by filling in the spaces provided. More complex proposals with more than minor effects will need to address the matters in accordance with the Fourth Schedule as a separate document.

**Show the location of the activity and the adjoining properties on your map on Form 1. Include design plans and details with this application.**

### Part A: General

#### 1. Type of Activity

What do you proposed to do and why? (eg. construct ford, divert creek, rock protection works)

Are you:	Yes	No
(1) Erecting, reconstructing, placing, altering, extending, removing, or demolishing any structure?	<input type="checkbox"/>	<input type="checkbox"/>
(2) Excavating, drilling, tunnelling or disturbing the bed?	<input type="checkbox"/>	<input type="checkbox"/>
(3) Depositing any substance?	<input type="checkbox"/>	<input type="checkbox"/>
(4) Reclaiming or draining the bed?	<input type="checkbox"/>	<input type="checkbox"/>

#### 2. Programme

What is the proposed commencement date of the work?

What is the proposed completion date of the work?

Requested expiry date of consent

Who will be undertaking the work?

What are the proposed hours of operation/construction?

#### 3. Site Details

Name of the stream/river where the works will occur (if the waterway is an unnamed tributary then what is the name of the stream/river it flows into?)

What is the scale of the proposal?

(a) area of stream/river bed affected

length (m)

(b) length of works (eg if rock protection work)

## Part B: Description of Proposal

A good understanding of the proposal is needed so we can see how it relates to the existing environment.

### 1. Please describe how the work will be carried out:

**For structures** – please describe the general design of the structure or works required in the watercourse, the materials to be used, and the construction methods to be employed.

*If there are engineering plans of the proposed structure or plans of the works please enclose a copy with the application. Please include your own diagram on a separate page, if this will assist in describing the proposal, and attach it to this application form.*

### 2. Will the work be completed out in stages?

Yes

No

If so, in what stages?

### 3. Is the work: permanent temporary ?

## Part C: Assessment of Effects on the Environment

*This is the most important section that the Council considers when dealing with your application.*

**Where your activity could have a significant adverse effect on the environment a more detailed environmental assessment is required in accordance with the Fourth Schedule of the Resource Management Act 1991. A Consents Officer can discuss this with you.**

### 1. DESCRIPTION OF THE NATURAL ENVIRONMENT

Our environment is made up of many components. Completing this section helps identify issues relating to the proposal.

**Describe the following aspects of the environment in the immediate vicinity of the proposal and the effects on them of your proposal**

- a) bed material (eg rocky, silty etc)
- b) bank material
- c) any biota (eg fish, eels, insect life)
- d) the flow in the stream/river
- e) the water quality

**2. DESCRIPTION OF THE HUMAN AND BUILT ENVIRONMENT**

Please describe the following aspects of the environment and the **approximate distance** from the location of your proposal to them.

(a) Any built structures such as bridges, culverts, roads, buildings etc

.....

.....

.....

(b) Location and proximity of neighbours to the proposal

.....

.....

.....

(c) Areas of aesthetic or scientific value (eg. archaeological sites, historic sites, scenic waterfalls)

.....

.....

.....

(d) Recreational activities carried out (eg. swimming, walking, fishing, canoeing)

.....

.....

.....

(e) Areas or aspects of significance to iwi

.....

.....

.....

3. Describe what effects your proposed activity may have and the steps you propose to take to mitigate these (eg. sediment control, erosion work). Also identify any safeguards and contingency plans where relevant.

**4. Are there any alternative locations for carrying out the work.**

Yes  No

If Yes, where?

**Are there any alternative methods for carrying out the work**

Yes  No

If Yes, what are the alternative methods?

#### **5. MONITORING**

What sort of monitoring do you proposed to undertake

a) While carrying out the activity?

b) Following completion of the activity?

**APPLICNS**

## Construction of a Bridge

Please fill in the dimensions on the diagram in the list below (if the bridge design is different from that below please include a diagram showing all dimensions).

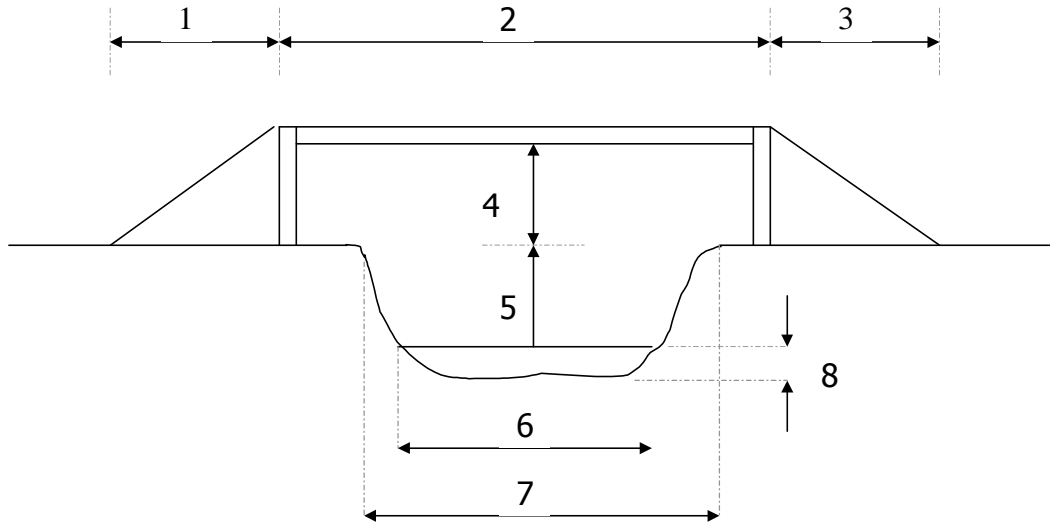

- |  |              |
|--|--------------|
| 1. Length of bridge approach                             | _____ metres |
| 2. Length of bridge                                      | _____ metres |
| 3. Length of bridge approach                             | _____ metres |
| 4. Height of bridge underside above natural ground level | _____ metres |
| 5. Height of natural ground level above stream bed       | _____ metres |
| 6. Bed width of stream channel                           | _____ metres |
| 7. Top width of stream                                   | _____ metres |
| 8. Average depth of water in the stream                  | _____ metres |

**Will the abutments of the bridge be outside the banks of the waterway, in the banks of the waterway or in the bed of the waterway? Please explain.**

## Construction of a Culvert

**What is the proposed culvert to be made of?**

**What is the length of the culvert you intend to place in the stream?**

**At what gradient will the culvert be laid in the stream bed?**

**What is the fill material to be used over the culvert?**

Please fill in the dimensions on the diagram in the list below (if the bridge design is different from that below please include a diagram showing all dimensions).

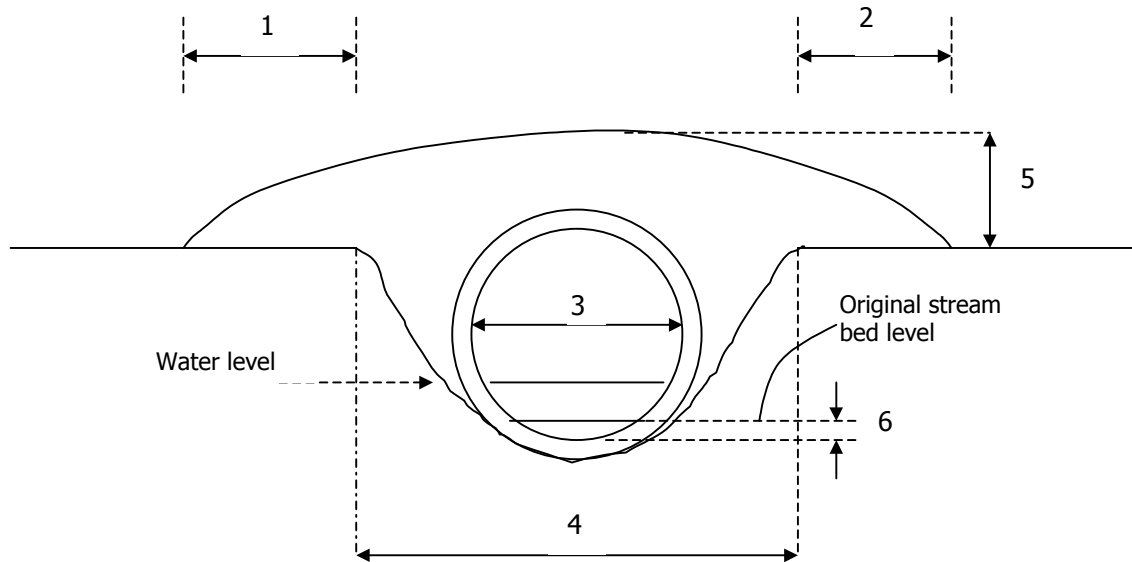

- |  |              |
|--|--------------|
| 1. Length of culvert approach                            | _____ metres |
| 2. Length of culvert approach                            | _____ metres |
| 3. Diameter of culvert (if circular)                     | _____ metres |
| If box culvert then, width _____ metres, height          | _____ metres |
| 4. Top width of original stream                          | _____ metres |
| 5. Depth of fill over culvert                            | _____ metres |
| 6. Depth of culvert base below original stream bed level | _____ metres |